

(19)



Europäisches Patentamt  
European Patent Office  
Office européen des brevets



(11) EP 1 352 969 A1

(12)

**EUROPEAN PATENT APPLICATION**

(43) Date of publication:  
15.10.2003 Bulletin 2003/42

(51) Int Cl.7: C12Q 1/00, G01N 27/327

(21) Application number: 03013425.8

(22) Date of filing: 10.07.1995

(84) Designated Contracting States:  
DE FR GB

(30) Priority: 17.03.1995 JP 5893995

(62) Document number(s) of the earlier application(s) in  
accordance with Art. 76 EPC:  
95110746.5 / 0 732 406

(71) Applicant: MATSUSHITA ELECTRIC INDUSTRIAL  
CO., LTD.  
Kadoma-shi, Osaka 571-8501 (JP)

(72) Inventors:  
• Ikeda, Shin  
Katano-shi, Osaka (JP)

- Yoshioka, Toshihiko  
Osaka-shi, Osaka (JP)
- Nankai, Shiro  
Hirakata-shi, Osaka (JP)

(74) Representative: Balsters, Robert et al  
Novagraaf International SA  
25, avenue du Pailly  
1220 Les Avanchets - Geneva (CH)

Remarks:

This application was filed on 20 - 06 - 2003 as a  
divisional application to the application mentioned  
under INID code 62.

(54) **A method and a device for quantifying a substrate in a sample liquid using a biosensor**

(57) A method and a device for quantifying a substrate in a sample liquid by use of a biosensor are provided. The biosensor can quantify the substrate by electrochemically measuring an amount of an electron acceptor that has been reduced by electrons generated in a reaction between the substrate in the sample liquid and an oxidoreductase. The biosensor includes: an electrically insulating substrate; an electrode system formed on the substrate including a working electrode, a counter electrode, and a third electrode used for detecting a liquid junction; and a reaction layer that is formed over at least the working electrode and the coun-

ter electrode of the electrode system and includes the oxidoreductase. The method includes the steps of: applying a voltage between the counter electrode and the third electrode; supplying the sample liquid to the reaction layer; detecting an electrical change between the counter electrode and the third electrode generated by the supply of the sample liquid to the reaction layer; applying a voltage to the working electrode after the detection using at least the third electrode as a reference; and measuring a current generated between the working electrode and the counter electrode.

EP 1 352 969 A1

BEST AVAILABLE COPY

## Description

### BACKGROUND OF THE INVENTION

#### 1. Field of the Invention:

[0001] The present invention relates to a method and a device for quantifying a substrate by using a biosensor that can easily quantify a substrate (a specific component) in a sample liquid with speed and accuracy. More particularly, the invention relates to a method and a device for quantifying a substrate by using a biosensor that can quantify a substrate in a sample liquid by electrochemically measuring the amount of an electron acceptor that has been reduced with an electron generated in a reaction between the substrate in the sample liquid and an oxidoreductase that specifically reacts with the substrate.

#### 2. Description of the Related Art:

[0002] The optical rotation method, the colorimetric method, the reductimetry method and other methods using different kinds of chromatographies have been developed as methods for quantitative analysis of saccharides such as sucrose and glucose. However, none of these methods can provide high accuracy due to the relatively low specificity against saccharides. Among these methods, the optical rotation method is easy to operate but is largely influenced by the operating temperature. Therefore, it is not appropriate for common use at home and the like.

[0003] Various types of biosensors utilizing a specific catalysis of an enzyme have been recently developed. As an example of methods for quantifying a substrate in a sample liquid, a method for quantifying glucose will now be described. For electrochemically quantifying glucose, a method using glucose oxidase (EC1.1.3.4; hereinafter referred to as GOD) and an oxygen electrode or a hydrogen peroxide electrode is generally known (for example, "Biosensor" edited by Shuichi Suzuki, Kodansha Kabushiki Kaisha).

[0004] GOD selectively oxidizes  $\beta$ -D-glucose into D-glucono- $\delta$ -lactone by using oxygen as an electron acceptor. In an oxidation reaction using GOD in the presence of oxygen, oxygen is reduced to hydrogen peroxide. In the aforementioned method, the amount of reduced oxygen is measured by using an oxygen electrode, or the amount of increased hydrogen peroxide is measured by using a hydrogen peroxide electrode. Since the amounts of the reduced oxygen and the increased hydrogen peroxide are in proportion to the content of glucose in the sample liquid, glucose can be quantified based on the amount of the reduced oxygen or the increased hydrogen peroxide.

[0005] The above-mentioned method, however, has a problem in that the measurement result is largely affected by the concentration of oxygen in the sample li-

quid, as can be presumed from the reaction process. Furthermore, when no oxygen is contained in the sample liquid, the above-mentioned method cannot be adopted.

[0006] In order to solve this problem, a new type of glucose sensor has been developed, in which an organic compound such as potassium ferricyanide, a ferrocene derivative and a quinone derivative or a metal complex is used as an electron acceptor instead of oxygen. In this type of sensor, the reduced form of an electron acceptor resulting from the enzymatic reaction is oxidized on an electrode, and the concentration of glucose contained in a sample liquid is obtained based on the amount of the measured oxidation current. By using an organic compound or a metal complex as an electron acceptor instead of oxygen, it is possible to hold a known amount of GOD and its electron acceptor on an electrode stably and accurately, so as to form a reaction layer. In this case, the reaction layer can be integrated with the electrode in a substantially dry state. Therefore, a disposable glucose sensor based on this technique has recently come to public notice. In this disposable glucose sensor, the concentration of glucose in a sample liquid can be easily measured with a measuring device merely by introducing the sample liquid into the sensor removably connected to the measuring device. Such a method can be applied not only to the quantification of glucose but also to the quantification of any other substrate contained in a sample liquid.

[0007] Japanese Laid-Open Patent Publication No. 6-109688 discloses a biosensor as shown in Figure 9. The biosensor includes a substrate 40, a cover 47, and a spacer 46 sandwiched between the substrate 40 and the cover 47. A sample supply port 48 is formed in the spacer 46, and an air port 49 is formed in the cover 47. When the cover 47 is placed over the substrate 40 with the spacer 46 therebetween so as to be adhered to one another, a space 50 which is open to the sample supply port 48 is defined by the substrate 40, the spacer 46, and the cover 47. The other end of the space 50 communicates with the air port 49.

[0008] On the substrate 40 are formed a working electrode 41, a counter electrode 42, an electrode 43 for detecting a liquid junction, and leads 41a, 42a, and 43a connected to these electrodes, respectively. A reaction layer 51 is formed over the working electrode 41, the counter electrode 42, and the electrode 43 for detecting a liquid junction. The reference numeral 52 in Figure 9 denotes an insulating layer.

[0009] The electrode 43 for detecting a liquid junction is formed at a position farther from the sample supply port 48 than the working electrode 41 and the counter electrode 42, so that a sample liquid supplied through the sample supply port 48 can first reach the working electrode 41 and the counter electrode 42 before reaching the electrode 43.

[0010] According to the above conventional biosensor, the fact that a sample liquid supplied through the sample supply port 48 has reached the reaction layer

51 can be detected by the electrode 43. Once the electrode 43 detects this fact, a voltage is applied between the working electrode 41 and the counter electrode 42 so as to obtain a current response. Thus, a current flowing between the working electrode 41 and the counter electrode 42 is measured, and the quantification is conducted based on the measurement result. However, when an voltage is applied between the working electrode 41 and the counter electrode 42 to obtain a current response as described above, the potential of the counter electrode 42 used as a reference may be varied by the oxidation-reduction reaction in some cases, causing errors and deviation in the measurement result on the amount of the substrate in the sample liquid.

#### SUMMARY OF THE INVENTION

[0011] The method for quantifying a substrate in a sample liquid of this example uses a biosensor. The biosensor can quantify the substrate by electrochemically measuring an amount of an electron acceptor that has been reduced by electrons generated in a reaction between the substrate in the sample liquid and an oxidoreductase, the biosensor comprising: an electrically insulating substrate; an electrode system formed on the substrate including a working electrode, a counter electrode, and a third electrode used for detecting a liquid junction; and a reaction layer that is formed over at least the working electrode and the counter electrode of the electrode system and includes the oxidoreductase. The method comprises the steps of: applying a voltage between the counter electrode and the third electrode; supplying the sample liquid to the reaction layer; detecting an electrical change between the counter electrode and the third electrode generated by the supply of the sample liquid to the reaction layer; applying a voltage to the working electrode after the detection using at least the third electrode as a reference; and measuring a current generated between the working electrode and the counter electrode.

[0012] In another aspect of the present invention, a device for quantifying a substrate in a sample liquid is provided. The device comprises a biosensor and a measuring device removably connected to the biosensor. The biosensor can quantify the substrate by electrochemically measuring an amount of an electron acceptor that has been reduced by electrons generated in a reaction between the substrate in the sample liquid and an oxidoreductase, the biosensor comprising: an electrically insulating substrate; an electrode system formed on the substrate including a working electrode, a counter electrode and a third electrode used for detecting a liquid junction; and a reaction layer that is formed over at least the working electrode and the counter electrode of the electrode system and includes the oxidoreductase. The device comprises: means for detecting an electrical change between the counter electrode and the third electrode generated by the supply of

the sample liquid to the reaction layer; means for applying a voltage to the working electrode after the detection using at least the third electrode as a reference; and means for measuring a current flowing between the working electrode and the counter electrode.

[0013] On one embodiment, the step of applying a voltage to the working electrode comprises a step of applying a voltage between the working electrode and the counter electrode and the third electrode.

[0014] In another embodiment, the counter electrode includes a main electrode portion formed in substantially a C-shape in a plane view and an opening formed in the main electrode portion, the working electrode is disposed inside of the counter electrode so as to be electrically insulated from each other, and a lead connected to the working electrode is led from the inside to the outside of the counter electrode through the opening.

[0015] In still another embodiment, a peripheral portion of the counter electrode is opened to provide an electrode receiving portion, and the third electrode is disposed within the electrode receiving portion.

[0016] In still another embodiment, the third electrode is disposed farther from a sample supply port than the working electrode and the counter electrode, so that a sample liquid supplied through the sample supply port reaches the third electrode after reaching the working electrode and the counter electrode.

[0017] In still another embodiment, the third electrode is disposed nearer to a sample supply port than the working electrode, so that a sample liquid supplied through the sample supply port reaches the third electrode before reaching the working electrode and the counter electrode.

[0018] In still another embodiment, the counter electrode includes a main electrode portion formed in substantially a C-shape in a plane view and an opening formed in the main electrode portion, the working electrode is disposed inside of the counter electrode so as to be electrically insulated from each other, a lead connected to the working electrode is led from the inside to the outside of the counter electrode through the opening, and the third electrode is disposed between the counter electrode and the working electrode so as to be electrically insulated from one another.

[0019] Thus, the invention described herein makes possible the advantages of (1) providing a method and a device for quantifying a substrate in which a third electrode is used as a reference for the simple, rapid and accurate quantification of a specific substrate in a sample liquid, so as to decrease errors and deviation in the measurement result on the amount of the substrate in the sample liquid; and (2) providing a method and a device for quantifying a substrate by use of a biosensor having a comparatively simple structure and the above-described characteristics.

[0020] These and other advantages of the present invention will become apparent to those skilled in the art upon reading and understanding the following detailed

description with reference to the accompanying figures.

#### **BRIEF DESCRIPTION OF THE DRAWINGS**

##### **[0021]**

Figure 1 is an exemplified circuit diagram for the biosensor used in this invention and a measuring device connected thereto.

Figure 2 is another exemplified circuit diagram for the biosensor used in this invention and a measuring device connected thereto.

Figure 3 is an exploded perspective view of a glucose sensor as an example of a biosensor used in this invention from which a reaction layer is removed.

Figure 4 is a plane view of a substrate having an electrode system used in a glucose sensor shown in Figure 3.

Figure 5 is a circuit diagram for the biosensor of Figure 3 and a measuring device connected thereto.

Figure 6 is a plane view of a substrate having an electrode system used in a glucose sensor as still another example of the biosensor used in this invention.

Figure 7 is a plane view of a substrate having an electrode system used in a glucose sensor as still another example of the biosensor used in this invention.

Figure 8 is a plane view of a substrate having an electrode system used in a glucose sensor as still another example of the biosensor used in this invention.

Figure 9 is an exploded perspective view of a conventional biosensor.

#### **DESCRIPTION OF THE PREFERRED EMBODIMENTS**

[0022] A biosensor used in this invention includes an electrically insulating substrate, an electrode system that is formed on the substrate and includes a working electrode, a counter electrode and a third electrode, and a reaction layer formed over the working electrode and the counter electrode of the electrode system. The working electrode, the counter electrode and the third electrode of the electrode system are preferably formed on the same plane on the substrate.

[0023] The electrically insulating substrate can be formed from a plate made of a synthetic resin such as

polyethylene terephthalate or any other suitable resin known in the art.

[0024] The electrode system including the working electrode, the counter electrode corresponding to the working electrode and the third electrode can be formed on the substrate by a known method. For example, after forming leads on the substrate, the working electrode, the counter electrode and the third electrode are formed so as to be connected to the respective leads and be insulated from one another. The material for the leads and the electrodes can be of any known conductive materials such as silver paste and carbon paste. Furthermore, a silver/silver chloride electrode can be used.

[0025] The shapes and the positions of the respective electrodes of the electrode system can be variously modified. For example, the counter electrode can be in the shape of a ring or be substantially a C-shape in a plane view. The working electrode can be positioned in a space within the ring-shaped or C-shaped counter electrode so as to be electrically insulated therefrom. By providing the working electrode inside of the counter electrode, these electrodes can be positioned adjacent to each other. In this case, the reaction layer covering the working electrode and the counter electrode can be easily formed.

[0026] When the counter electrode is formed so as to have a substantially C-shaped main electrode portion and an opening formed in the main electrode portion, a lead connected to the working electrode positioned inside of the main electrode portion is led from the inside to the outside of the main electrode portion through the opening.

[0027] In a peripheral portion of the counter electrode can be formed an electrode receiving portion for the third electrode. The shapes of the electrode receiving portion and the third electrode can be variously modified according to the required application. Furthermore, the position of the electrode receiving portion in the counter electrode can be varied depending upon the application of the biosensor.

[0028] For example, the third electrode can be positioned farther from a sample supply port of the biosensor than the working electrode and the counter electrode, so that a sample liquid supplied through the sample supply port can reach the third electrode after reaching the working electrode and the counter electrode. Alternatively, the third electrode can be positioned nearer to the sample supply port than the working electrode, so that a sample liquid supplied through the sample supply port can reach the third electrode before reaching the working electrode and the counter electrode.

[0029] When the third electrode is positioned farther from the sample supply port than the working electrode and the counter electrode, the change of a resistance value between the counter electrode and the third electrode cannot be detected until a space including all of the three electrodes is filled with a sample liquid. Accordingly, by utilizing such a third electrode for detecting

a liquid junction, it can be definitely determined whether or not a sample liquid supplied through the sample supply port has covered the entire reaction layer.

**[0030]** To the contrary, when the third electrode is positioned nearer to the sample supply port than the working electrode and the counter electrode, the third electrode is soaked with the supplied sample liquid without fail. Accordingly, by utilizing such a third electrode as a reference electrode, a reference potential can be more stabilized, resulting in attaining a measurement having less deviation.

**[0031]** The third electrode can also be positioned between the counter electrode and the working electrode so as to be electrically insulated therefrom.

**[0032]** The reaction layer can be formed over the working electrode and the counter electrode of the electrode system. Alternatively, the reaction layer can be formed over not only the working electrode and the counter electrode but also the third electrode.

**[0033]** The reaction layer can be formed with one layer or two layers including at least an enzyme (oxidoreductase), and more preferably further including an electron acceptor. When the reaction layer is formed with two layers, the two layers can be a first layer made of a hydrophilic polymer formed directly on the electrode system, and a second layer including at least an enzyme and an electron acceptor laminated on the first layer.

**[0034]** Examples of the hydrophilic polymer forming the first hydrophilic polymer layer include carboxy methyl cellulose (hereinafter referred to as CMC), hydroxyethyl cellulose (hereinafter referred to as HEC), hydroxypropyl cellulose (hereinafter referred to as HPC), methyl cellulose, ethyl cellulose, ethyl hydroxyethyl cellulose, carboxymethyl ethyl cellulose, polyvinyl pyrrolidone, polyvinyl alcohol, polyamino acids such as polylysine, polystyrene sulfonate, gelatin or its derivative, acrylic acid or its salt, methacrylic acid or its salt, starch or its derivative, and maleic anhydride or its salt. Among the above, CMC, HEC, HPC, methyl cellulose, ethyl cellulose, ethyl hydroxyethyl cellulose and carboxymethyl ethyl cellulose are preferred.

**[0035]** The kind of oxidoreductase contained in the reaction layer depends upon a substrate contained in a sample liquid to be quantified and is not herein specifically defined. Examples of the oxidoreductase include fructose dehydrogenase, invertase, mutarotase, glucose oxidase, alcohol oxidase, lactic acid oxidase, cholesterol oxidase, xanthine oxidase and amino acid oxidase.

**[0036]** Examples of the electron acceptor include potassium ferricyanide, p-benzoquinone, phenazine methosulfate, methylene blue and a ferrocene derivative. One or a combination of two or more of the above can be used as the electron acceptor.

**[0037]** The enzyme and the electron acceptor can be dissolved in a sample liquid, or the reaction layer is immobilized on the substrate or the like so as not to allow the enzyme and the electron acceptor to dissolve in a sample liquid. When the enzyme and the electron ac-

ceptor are immobilized, the reaction layer preferably includes the hydrophilic polymer.

**[0038]** The reaction layer can further include a pH buffer such as potassium dihydrogenphosphate - dipotassium hydrogenphosphate, potassium dihydrogenphosphate - disodium hydrogenphosphate, sodium dihydrogenphosphate - dipotassium hydrogenphosphate, sodium dihydrogenphosphate - disodium hydrogenphosphate, citric acid - disodium hydrogenphosphate, citric acid - dipotassium hydrogenphosphate, citric acid - sodium citrate, citric acid - potassium citrate, potassium dihydrogencitrate - sodium hydroxide, sodium dihydrogencitrate - sodium hydroxide, sodium hydrogenmaleate - sodium hydroxide, potassium hydrogenphthalate - sodium hydroxide, succinic acid - sodium tetraborate, maleic acid - tris(hydroxymethyl)aminomethane, tris(hydroxymethyl)aminomethane - tris(hydroxymethyl)aminomethane hydrochloride, [N-(2-hydroxyethyl)piperazine-N'-2-ethanesulfonic acid] - sodium hydroxide, [N-tris(hydroxymethyl)methyl-2-aminoethanesulfonic acid] - sodium hydroxide, and [piperazine-N,N'-bis(2-ethanesulfonic acid)] - sodium hydroxide.

**[0039]** The reaction layer can be formed by dropping on a substrate a solution including at least the enzyme and more preferably further including the electron acceptor and drying the dropped solution.

**[0040]** When the reaction layer is formed with the first hydrophilic polymer layer and the second layer that includes the enzyme and the electron acceptor and is laminated on the first layer, the second layer can be formed by, for example, dropping a mixed solution of the enzyme and the electron acceptor on the first layer.

**[0041]** The thus-formed biosensor can be removably connected to a measuring device A shown in Figure 1 or 2.

**[0042]** Referring to Figures 1 and 2, the biosensor B includes an electrode system formed on a substrate including a working electrode 5, a counter electrode 8 and a third electrode 7 used for detecting a liquid junction. The working electrode 5 is connected to a terminal 2a via a lead 2. The counter electrode 8 is connected to a terminal 4a via a lead 4. The third electrode 7 is connected to a terminal 3a via a lead 3. The measuring device A shown in Figure 1 includes a connector 25 having terminals 31, 32 and 33 which can be connected to the respective terminals 2a, 3a and 4a of the biosensor B, current/voltage converting circuits 26 connected to the terminal 32 of the connector 25, A/D converting circuits 27 connected to the respective current/voltage converting circuits 26, current/voltage converting circuits 26a which can be connected to the terminal 31 via a switch 29, A/D converting circuits 27a connected to the respective current/voltage converting circuits 26a, and a controller 28 including a microcomputer and the like connected to the respective A/D converting circuits 27 and 27a. The above-mentioned switch 29 is ON/OFF controlled by the controller 28.

**[0043]** An operation of a circuit including the biosen-

sor **B** and the measuring device **A** of Figure 1 will be described.

[0044] First, the biosensor **B** is connected to the measuring device **A**. At this time, the switch **29** is disconnected from the terminal **31** by the controller **28**. On the other hand, a predetermined voltage (e.g., 0.5 volts) is applied between the counter electrode **8** and the third electrode **7**. When a sample liquid is supplied to the biosensor **B** under this condition, a current flows between the counter electrode **8** and the third electrode **7**. The value of this current is detected by the controller **28**. Based on this detection, a time is measured. After a predetermined period of time, the switch **29** is switched to the terminal **31** and a predetermined voltage (e.g., 0.5 volts) is applied to the working electrode **5** using at least the third electrode as a reference. For example, a fixed voltage (e.g., 0.5 volts) required for obtaining a response current is applied between the working electrode **5** and the counter electrode **8** and the third electrode **7**. A current thus flowing between the working electrode **5** and the counter electrode **8** is converted into a voltage by the current/voltage converting circuits **26a**, and the obtained voltage value is converted into the number of pulses in a fixed period of time by the A/D converting circuits **27a**. The controller **28** counts up the number of the pulses, calculates a response value, and indicates the result.

[0045] Therefore, when a sample liquid including a substrate (for example, a saccharide) is supplied to the biosensor **B**, the reaction layer is dissolved in the sample liquid. After a predetermined period of time from the supply of the sample liquid, a fixed voltage is applied between the working electrode **5** and the counter electrode **8**. Then, after a predetermined period of time, a current value of a current flowing through the electrodes is measured. The obtained current value is in proportion to the concentration of the substrate in the sample liquid. A large number of current values are previously measured with regard to a plurality of sample liquids including the substrate at various known concentrations so as to obtain the relationship between the concentration and the current value. Then, the substrate contained in a sample liquid at an unknown concentration can be quantified by measuring a current value as described above.

[0046] In such a quantifying method in which the change of the concentration of a substrate caused through the reaction between an enzyme and the substrate in a sample liquid is measured based upon an electrochemical response obtained by applying a voltage to the working electrode **5**, when the third electrode **7** is used, as a reference electrode, in addition to the working electrode **5** and the counter electrode **8**, the deviation of a reference potential can be substantially ignored.

[0047] Furthermore, when the third electrode **7** is used for detecting a liquid junction, even though there is no need to apply a voltage between the working electrode **5** and the counter electrode **8** for the detection of

the liquid junction as is conventionally applied, the supply of the sample liquid can be detected without fail. Furthermore, when the third electrode **7** is commonly used as a reference electrode and a liquid junction detecting electrode, the structure of the electrode system can be simplified.

[0048] The measuring device **A** shown in Figure 2 includes a connector **25** having terminals **31**, **32** and **33** connected to the respective terminals **2a**, **3a** and **4a** of the biosensor **B**, current/voltage converting circuits **26** connected to the respective terminals **31** or **32** of the connector **25** via a switch **29**, A/D converting circuits **27** connected to the respective current/voltage converting circuits **26**, a controller **28** including a microcomputer and the like connected to the respective A/D converting circuits **27**. The above-mentioned switch **29** is ON/OFF controlled by the controller **28**.

[0049] An operation of a circuit including the biosensor **B** and the measuring device **A** of Figure 2 will be described.

[0050] First, the biosensor **B** is connected to the measuring device **A**. At this time, the switch **29** is connected to the terminal **32** by the controller **28**. A predetermined voltage (e.g., 0.5 volts) is applied between the counter electrode **8** and the third electrode **7**. When a sample liquid is supplied to the biosensor **B** under this condition, a current flows between the counter electrode **8** and the third electrode **7**. The value of this current is detected by the controller **28**. Based on this detection, a time is measured. After a predetermined period of time, the switch **29** is switched to the terminal **31** and a predetermined voltage (e.g., 0.5 volts) is applied to the working electrode **5**. A fixed voltage (e.g., 0.5 volts) required for obtaining a response current is applied between the working electrode **5** and the counter electrode **8** and the third electrode **7** of the biosensor **B**.

[0051] A current thus flowing between the working electrode **5** and the counter electrode **8** is converted into a voltage by the current/voltage converting circuits **26**, and the obtained voltage value is converted into the number of pulses in a fixed period of time by the A/D converting circuits **27**. The controller **28** counts up the number of the pulses, calculates a response value, and indicates the result.

[0052] The measuring device **A** shown in Figure 1 requires the current/voltage converting circuits **26** and **26a**, and the A/D converting circuits **27** and **27a**, respectively for the working electrode **5** and the counter electrode **8**. In the measuring device **A** shown in Figure 2, the current/voltage converting circuits **26** and the A/D converting circuits **27** can be commonly used for the working electrode **5** and the counter electrode **8**.

[0053] According to this invention, saccharides in fruits and saccharides in blood, lymph, urine, and saliva can be quantified. The biosensor which can be used in this invention includes, for example, a fructose sensor, a sucrose sensor, a glucose sensor, an alcohol sensor, a lactic acid sensor, a cholesterol sensor and an amino

acid sensor.

#### Examples

[0054] Throughout the drawings mentioned in the following description, the same element has a common reference numeral, and the description is omitted as occasion demands.

#### Example 1

[0055] In this example, a method for quantifying glucose will be described. A glucose sensor shown in Figure 3 was used. Figure 3 is an exploded perspective view of a glucose sensor from which a reaction layer is removed. The glucose sensor includes an insulating substrate 1 made of polyethylene terephthalate, a cover 9, and a spacer 10 sandwiched between the substrate 1 and the cover 9. The substrate 1, the spacer 10 and the cover 9 are adhered to one another in the positional relationship as is shown with broken lines in Figure 3, thereby forming the glucose sensor.

[0056] A sample supply port 11 is formed in the spacer 10, and an air port 12 is formed in the cover 9. When the cover 9 is adhered to the substrate 1 with the spacer 10 interposed therebetween, the substrate 1, the spacer 10 and the cover 9 form a space (not shown) communicated with the sample supply port 11, and the end portion of the space is communicated with the air port 12.

[0057] As shown in Figure 4, on the substrate 1 are formed a working electrode 5, a third electrode 7, a counter electrode 8, and leads 2, 3 and 4 electrically connected to these electrodes, respectively. The counter electrode 8 includes a substantially C-shaped main electrode portion and an opening 21 formed in the main electrode portion. The lead 2 connected to the working electrode 5 is led from the inside to the outside of the counter electrode 8 through the opening 21.

[0058] The third electrode 7 is positioned farther from an inlet 11a of the sample supply port 11 than the working electrode 8. Over the electrode system excluding the third electrode 7 (i.e., the working electrode 5 and the counter electrode 8) is formed a reaction layer (not shown). A reference numeral 6 in Figure 1 denotes an insulating layer.

[0059] The working electrode 5, the counter electrode 8 and the third electrode 7 are exposed to the above-mentioned space.

This glucose sensor was manufactured as follows:

[0060] Silver paste was printed by screen printing on the insulating substrate 1 made of polyethylene terephthalate, thereby forming the leads 2, 3 and 4. Then, conductive carbon paste including a resin binder was printed on the substrate 1, thereby forming the working electrode 5 and the counter electrode 8. The working electrode 5 is in contact with the lead 2, while the counter

electrode 8 is in contact with the lead 4.

[0061] Next, insulating paste was printed on the resultant substrate 1, thereby forming the insulating layer 6. The insulating layer 6 covered the peripheral of the working electrode 5, so as to expose a fixed area of the working electrode 5. The insulating layer 6 also covered part of the leads 2, 3 and 4. The third electrode 7 was formed by exposing an end of the lead 3.

[0062] Then, conductive carbon paste including a resin binder was printed on the resultant substrate 1, thereby forming the counter electrode 8 so as to be in contact with the lead 4.

[0063] Next, an aqueous solution of CMC was dropped on the electrode system excluding the third electrode 7 (i.e., the working electrode 5 and the counter electrode 8) to be dried, thereby forming a CMC layer. Furthermore, an aqueous solution including GOD as an enzyme and potassium ferricyanide as an electron acceptor was dropped on the electrode system excluding the third electrode 7 (i.e., the working electrode 5 and the counter electrode 8) to be dried. Thus, the reaction layer was formed.

[0064] In order to attain a smoother supply of a sample liquid to the reaction layer, an organic solvent solution of lecithin (for example, a toluene solution) was spread from the inlet 11a of the sample supply port 11 over the entire reaction layer to be dried, thereby forming a lecithin layer. After this, the substrate 1, the cover 9 and the spacer 10 were adhered to one another as is shown with the broken lines in Figure 1. The glucose sensor was thus manufactured.

[0065] The glucose sensor B was then connected to the measuring device A having a circuit shown in Figure 5.

[0066] The glucose sensor B includes the electrode system formed on the substrate 1 having the working electrode 5, the counter electrode 8, and the third electrode 7 used for detecting a liquid junction. The working electrode 5 is connected to a terminal 2a via a lead 2. The counter electrode 8 is connected to a terminal 4a via a lead 4. The third electrode 7 is connected to a terminal 3a via a lead 3.

[0067] The measuring device A includes a connector 14 having terminals 16 and 15 and a grounding terminal 17 connected to the terminals 2a, 3a, and 4a of the glucose sensor, respectively, a current detection portion 18 connected to the terminal 15 of the connector 14, an A/D converting circuit 19 which can be connected to the terminal 16 via a switch 13, and a controller 20 composed of a microcomputer and the like.

[0068] The terminal 3a is applied with a fixed voltage. Accordingly, when a sample liquid is supplied to the glucose sensor B, the current detection portion 18 detects a current flowing through the electrode 7, so as to activate a system for detecting the supply of the sample liquid. Then, a measurement timer is started via the controller 20.

[0069] After a predetermined period of time has

passed, for example, after 55 seconds, the switch 13 is switched by a signal from the controller 20 so as to connect the terminal 16 to the A/D converting circuit 19. Thus, a fixed voltage required for obtaining a response current is applied between the working electrode 5 and the counter electrode 8 and the third electrode 7 of the glucose sensor B. The current flowing between the working electrode 5 and the counter electrode 8 is converted into a voltage. The obtained voltage value is in turn converted into the number of pulses in a fixed period of time by the A/D converting circuit 19. The controller 20 counts the number of pulses, calculates a response value, and indicates the result.

[0070] The glucose sensor was supplied with 3  $\mu$ l of an aqueous solution of glucose as a sample liquid through the sample supply port 11. The sample liquid reached the air port 12 through the space, and the reaction layer on the electrode system was dissolved therein.

[0071] Simultaneously with the supply of the sample liquid, a system for detecting the supply of a sample liquid based on the change of a resistance value between the counter electrode 8 and the third electrode 7 was operated, thereby actuating the measurement timer. After 55 seconds, a desired potential on the basis of the potential at the third electrode 7 was applied to the working electrode 5, and after 5 seconds, a current value was measured. A reaction is effected among ferricyanide ions, glucose and GOD in the sample liquid, resulting in the oxidation of glucose into glucono lactone and reduction of the ferricyanide ions into ferrocyanide ions. A current response can be obtained by oxidizing the ferrocyanide ions. In this manner, a current value depending upon the concentration of glucose in the sample liquid was obtained.

[0072] In this example, the case where the reaction layer is not formed over the third electrode 7 is described, but also when a reaction layer was formed over the third electrode 7, the same result was obtained.

[0073] Furthermore, the biosensor with the cover 9 is described in this example, but also when a biosensor without the cover 9 was used, a sensor response depending upon the concentration of glucose was obtained.

#### Example 2

[0074] The electrode system of a glucose sensor used in this example is shown in Figure 6.

[0075] In this glucose sensor, a peripheral portion, which is farther from a sample supply port 11, of a substantially C-shaped counter electrode 8 formed on a substrate 1 is opened to provide an electrode receiving portion 22. A third electrode 7 is provided within the electrode receiving portion 22. A reaction layer is formed over not only a working electrode 5 and the counter electrode 8 but also over the third electrode 7. The configuration of this glucose sensor is substantially identical to

that of Example 1 except for the above.

[0076] The glucose sensor was manufactured in the same manner as in Example 1 except that the reaction layer was formed over the third electrode 7 as well as over the working electrode 5 and the counter electrode 8.

[0077] The glucose sensor was supplied with 3  $\mu$ l of an aqueous solution of glucose as a sample liquid through the sample supply port 11, and a response current value was measured in the same manner as in Example 1. As a result, a current response depending upon the concentration of glucose in the sample liquid was obtained as in Example 1.

[0078] In the glucose sensor of this example, the third electrode 7 is formed in the electrode receiving portion 22 provided to the counter electrode 8, and hence, the reaction layer can be easily formed over the third electrode 7. Furthermore, a distance between the working electrode 8 and the third electrode 7 is decreased, resulting in reducing the effect of a voltage decrease in the application of the potential.

#### Example 3

[0079] The electrode system of a glucose sensor used in this example is shown in Figure 7.

[0080] In this glucose sensor, a peripheral portion, which is nearer to a sample supply port 11, of a substantially C-shaped counter electrode 8 formed on a substrate 1 is opened to provide an electrode receiving portion 22. A third electrode 7 is provided within the electrode receiving portion 22. A reaction layer is formed over not only a working electrode 5 and the counter electrode 8 but also the third electrode 7. The configuration of this glucose sensor is substantially identical to that of Example 1 except for the above.

[0081] The glucose sensor was manufactured in the same manner as in Example 1 except that the reaction layer was formed over the third electrode 7 as well as over the working electrode 5 and the counter electrode 8.

[0082] The glucose sensor was provided with 3  $\mu$ l of an aqueous solution of glucose as a sample liquid through the sample supply port 11, and a response current value was measured in the same manner as in Example 1. As a result, a current response depending upon the concentration of glucose in the sample liquid was obtained as in Example 1.

[0083] Furthermore, in the glucose sensor of this example, since the third electrode 7 is formed nearer to the sample supply port 11 on the substrate 1, the third electrode 7 can be soaked with the supplied sample liquid without fail. Therefore, when the third electrode 7 is used as a reference electrode, a reference potential is more stabilized, resulting in less deviation of the response values.



Example 4

[0084] The electrode system of a glucose sensor used in this example is shown in Figure 8.

[0085] In this glucose sensor, a substantially C-shaped counter electrode 8 is provided on a substrate 1, and a working electrode 5 is provided inside of the counter electrode 8. A third electrode 7 is formed in a substantial C-shape within a space 23 between the working electrode 5 and the counter electrode 8. A reaction layer is formed over not only the working electrode 5 and the counter electrode 8 but also the third electrode 7. The configuration of this glucose sensor is substantially identical to that of Example 1 except for the above.

The glucose sensor was manufactured as follows:

[0086] Silver paste was printed on the insulating substrate 1 made of polyethylene terephthalate by screen printing, thereby forming leads 2, 3 and 4. Then, conductive carbon paste including a resin binder was printed on the substrate 1, thereby forming the working electrode 5 and the third electrode 7, so that the working electrode 5 be in contact with the lead 2 and the third electrode 7 be in contact with the lead 3.

[0087] Next, insulating paste was printed on the resultant substrate 1, thereby forming an insulating layer 6. The insulating layer 6 covered the peripherals of the working electrode 5 and the third electrode 7, thereby exposing fixed areas of the working electrode 5 and the third electrode 7. Furthermore, the insulating layer 6 covered part of the leads 2, 3 and 4.

[0088] Then, conductive carbon paste including a resin binder was printed on the resultant substrate 1, thereby forming the counter electrode 8 so as to be in contact with the lead 4.

[0089] The manufacturing procedures thereafter were identical to those in Example 1, and the glucose sensor was thus manufactured.

[0090] The glucose sensor was supplied with 3  $\mu$ l of an aqueous solution of glucose as a sample liquid through the sample supply port 11, and a response current value was measured in the same manner as in Example 1. As a result, a current response depending upon the concentration of glucose in the sample liquid was obtained as in Example 1.

[0091] Furthermore, in the glucose sensor of this example, since the third electrode 7 is formed at the peripheral of the working electrode 5, the potential application to the working electrode 5 can be more stabilized in using the third electrode 7 as a reference electrode. As a result, the sensor response characteristic is improved.

[0092] Various other modifications will be apparent to and can be readily made by those skilled in the art without departing from the scope and spirit of this invention. Accordingly, it is not intended that the scope of the

claims appended hereto be limited to the description as set forth herein, but rather that the claims be broadly construed.

**Claims**

1. A method for quantifying a substrate in a sample liquid by use of a biosensor, the biosensor capable of quantifying the substrate by biochemically measuring an amount of an electron acceptor that has been reduced by electrons generated in a reaction between the substrate in the sample liquid and an oxidoreductase, the method comprising:

providing a said biosensor comprising:

an electrically insulation substrate;  
an electrode system formed on the substrate including a working electrode (5), a counter electrode (8), and a third electrode (7) used for detecting a liquid junction; and  
a reaction layer that is formed over at least the working electrode and the counter electrode of the electrode system and includes the oxidoreductase,

and the method comprising the steps of:

applying a voltage between the counter electrode (8) and the third electrode (7);  
supplying the sample liquid to the reaction layer;  
detecting an electrical change between the counter electrode (8) and the third electrode (7) generated by the supply of the sample liquid to the reaction layer;  
applying a voltage to the working electrode (5) after the detection; and  
measuring a current generated between the working electrode (5) and the counter electrode (7);

**characterised in that** the reaction layer is formed over the electrode system except the third electrode (7).

2. A method according to claim 1,
  - wherein the counter electrode includes a main electrode portion formed in substantially a C-shape in a plane view and an opening formed in the main electrode portion,
  - the working electrode is disposed inside of the counter electrode so as to be electrically insulated from each other, and
  - a lead connected to the working electrode is led from the inside to the outside of the counter electrode through the opening.

3. A method according to claim 1 or 2,  
 wherein the third electrode is disposed farther  
 from a sample supply port than the working elec-  
 trode and the counter electrode, so that a sample  
 liquid supplied through the sample supply port  
 reaches the third electrode after reaching the work-  
 ing electrode and the counter electrode.

reaches the third electrode after reaching the work-  
 ing electrode and the counter electrode.

4. A device for quantifying a substrate in a sample liq-  
 uid comprising a biosensor and a measuring device  
 to which the biosensor is removably connected, the  
 biosensor capable of quantifying the substrate by  
 electrochemically measuring an amount of an elec-  
 tron acceptor that has been reduced by electrons  
 generated in a reaction between the substrate in the  
 sample liquid and an oxidoreductase, the biosensor  
 comprising:

an electrically insulating substrate;  
 an electrode system formed on the substrate  
 including a working electrode (5), counter elec-  
 trode (8) and a third electrode (7) used for de-  
 tecting a liquid junction; and  
 a reaction layer that is formed over at least the  
 working electrode and the counter electrode of  
 the electrode system and includes the oxidore-  
 ductase, the device comprising;  
 means for detecting an electrical change be-  
 tween the counter electrode (8) and the third  
 electrode (7) generated by the supply of the  
 sample liquid to the reaction layer;  
 means for applying a voltage to the working  
 electrode (5) after the detection; and  
 means for measuring a current flowing between  
 the working electrode (5) and the counter elec-  
 trode (8);

**characterised in that** the reaction layer is  
 formed over the electrode system except the third  
 electrode (7).

5. A device according to claim 4,  
 wherein the counter electrode includes a main  
 electrode portion formed in substantially a C-shape  
 in a plane view and an opening formed in the main  
 electrode portion,  
 the working electrode is disposed inside of the  
 counter electrode so as to be electrically insulated  
 from each other, and  
 a lead connected to the working electrode is  
 led from the inside to the outside of the counter elec-  
 trode through the opening.

6. A device according to claim 4 or 5,  
 wherein the third electrode is disposed farther  
 from a sample supply port than the working elec-  
 trode and the counter electrode, so that a sample  
 liquid supplied through the sample supply port

FIG. 1

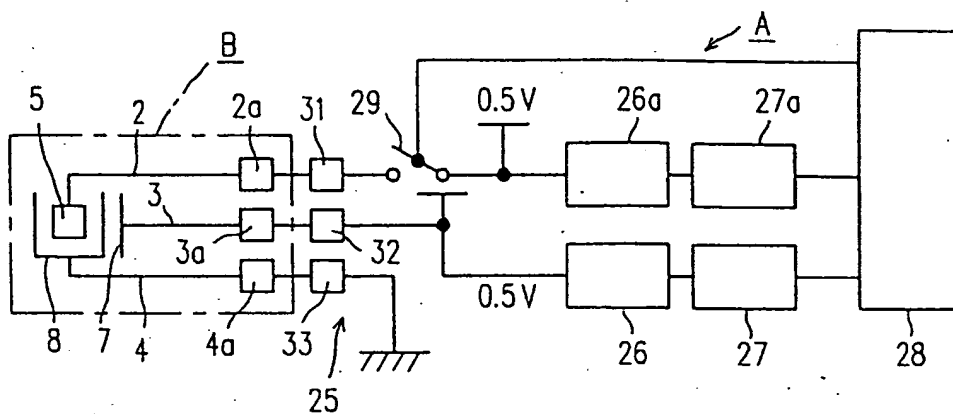

FIG. 2

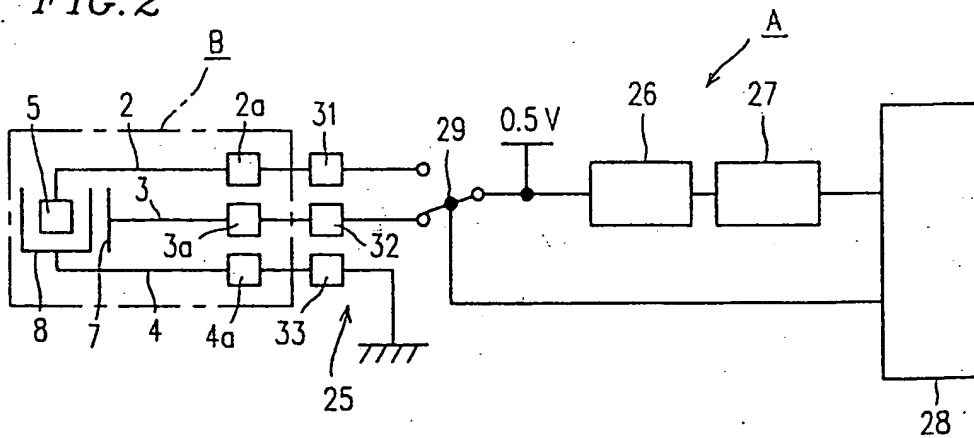

FIG. 3

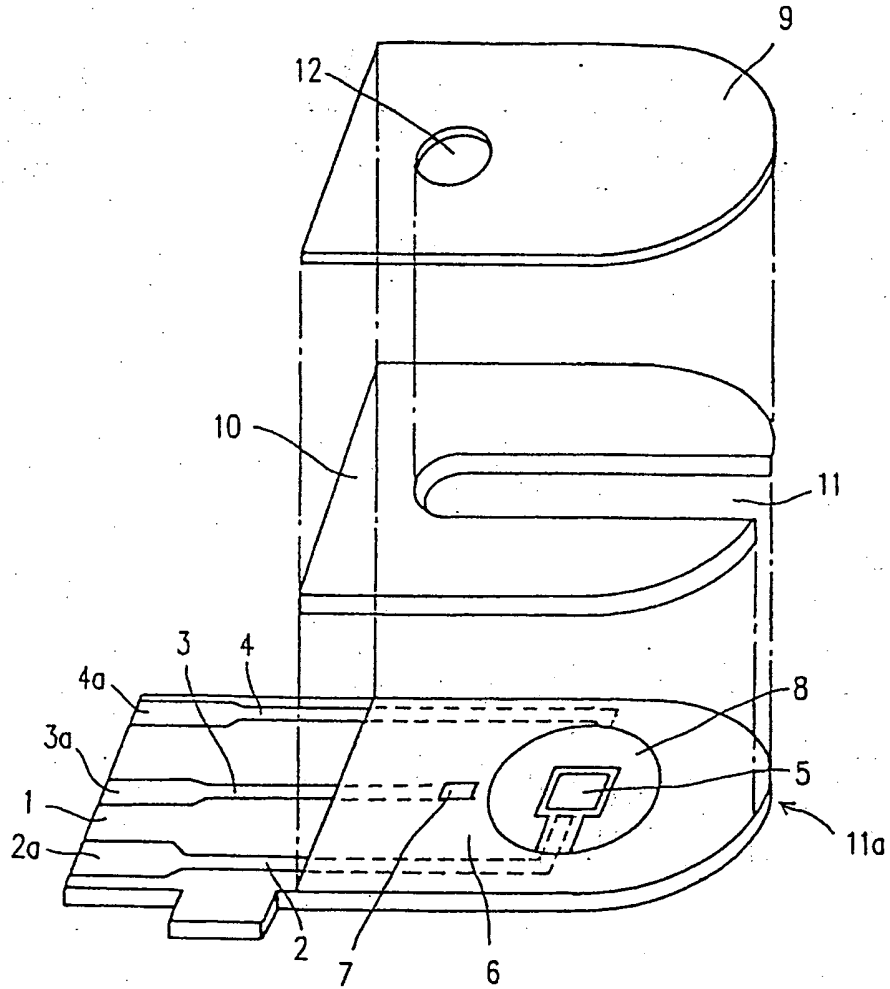

FIG. 4

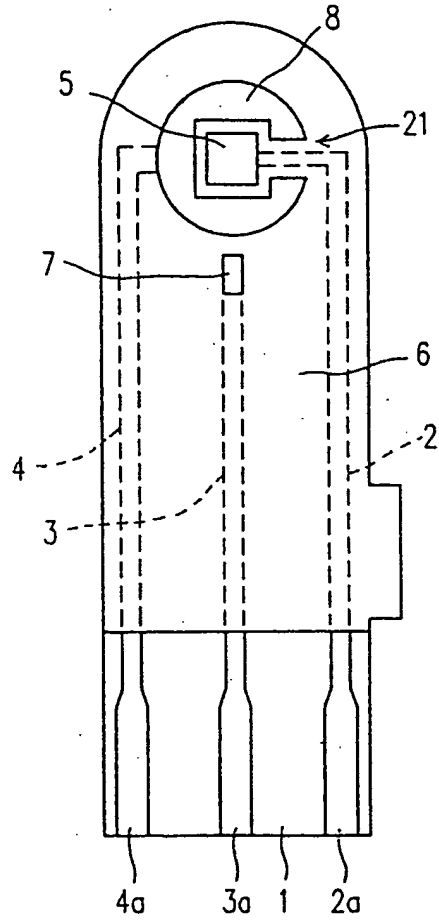

FIG. 5

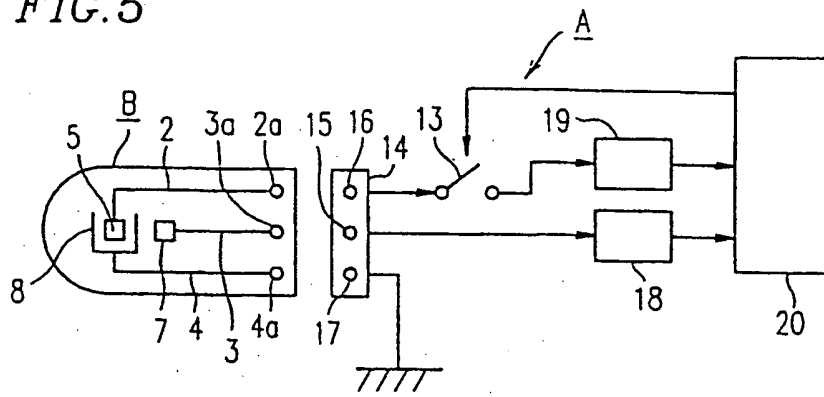

FIG. 6

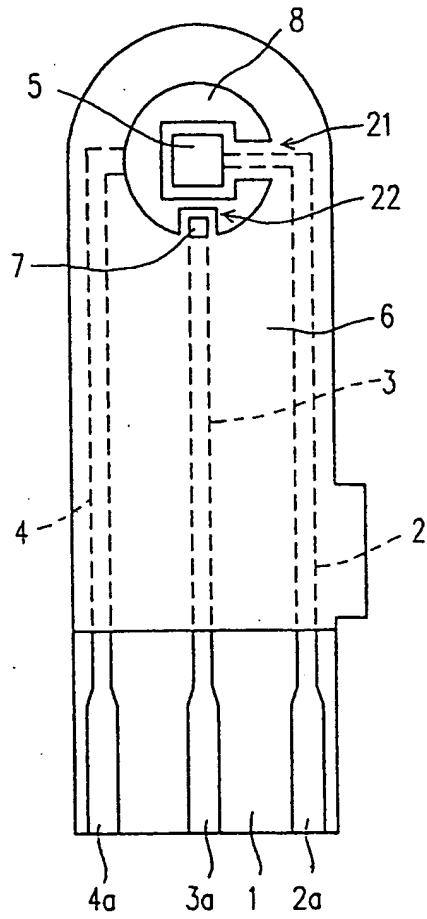

FIG. 7

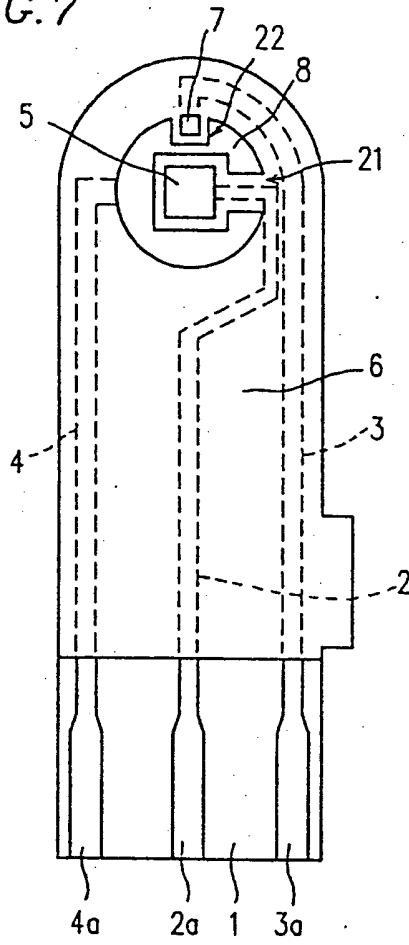



FIG. 8

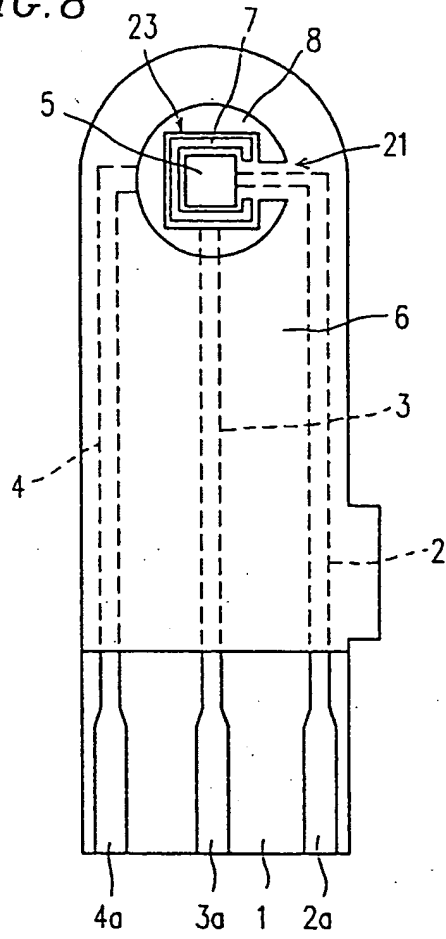
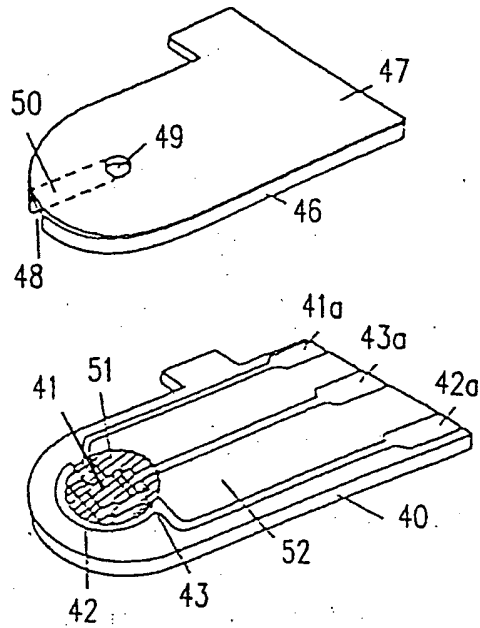

FIG.9 PRIOR ART





European Patent  
Office

EUROPEAN SEARCH REPORT

Application Number  
EP 03 01 3425

DOCUMENTS CONSIDERED TO BE RELEVANT			
Category	Citation of document with indication, where appropriate, of relevant passages	Relevant to claim	CLASSIFICATION OF THE APPLICATION (Int.CI.7)
A	EP 0 359 831 A (MATSUSHITA ELECTRIC IND CO LTD) 28 March 1990 (1990-03-28) * figure 4 *	1,8	C12Q1/00 G01N27/327
A	EP 0 537 761 A (MATSUSHITA ELECTRIC IND CO LTD) 21 April 1993 (1993-04-21) * the whole document *	1,8	
A	EP 0 502 504 A (MATSUSHITA ELECTRIC IND CO LTD) 9 September 1992 (1992-09-09) * figure 6 *	1,8	
A	DE 41 15 795 A (EKF IND ELEKTRONIK GMBH) 12 November 1992 (1992-11-12) * the whole document *	1,8	
The present search report has been drawn up for all claims			TECHNICAL FIELDS SEARCHED (Int.CI.7)
			C12Q G01N
Place of search	Date of completion of the search	Examiner	
THE HAGUE	11 August 2003	Moreno, C	
CATEGORY OF CITED DOCUMENTS		T: theory or principle underlying the invention E: earlier patent document, but published on, or after the filing date D: document cited in the application L: document cited for other reasons &: member of the same patent family, corresponding document	
X: particularly relevant if taken alone Y: particularly relevant if combined with another document of the same category A: technological background O: non-written disclosure P: intermediate document			

EPO FORM 1503 03 82 (PRO/C01)

ANNEX TO THE EUROPEAN SEARCH REPORT  
ON EUROPEAN PATENT APPLICATION NO.

EP 03 01 3425

This annex lists the patent family members relating to the patent documents cited in the above-mentioned European search report. The members are as contained in the European Patent Office EDP file on The European Patent Office is in no way liable for these particulars which are merely given for the purpose of information.

11-08-2003

Patent document cited in search report	Publication date	Patent family member(s)	Publication date
EP 0359831 A	28-03-1990	JP 1291153 A	22-11-1989
		JP 1932654 C	26-05-1995
		JP 6058338 B	03-08-1994
		JP 2062952 A	02-03-1990
		JP 2502666 B2	29-05-1996
		JP 1253648 A	09-10-1989
		JP 2502665 B2	29-05-1996
		DE 68924026 D1	05-10-1995
		DE 68924026 T2	21-03-1996
		EP 0359831 A1	28-03-1990
		US 5120420 A	09-06-1992
		WO 8909397 A1	05-10-1989
EP 0537761 A	21-04-1993	DE 69221808 D1	02-10-1997
		DE 69221808 T2	02-04-1998
		EP 0537761 A2	21-04-1993
		EP 0735363 A1	02-10-1996
		JP 2960265 B2	06-10-1999
		JP 5340915 A	24-12-1993
		US 5264103 A	23-11-1993
		JP 2658769 B2	30-09-1997
		JP 5196596 A	06-08-1993
EP 0502504 A	09-09-1992	DE 69220591 D1	07-08-1997
		DE 69220591 T2	18-12-1997
		EP 0502504 A1	09-09-1992
		JP 2671693 B2	29-10-1997
		JP 5119013 A	14-05-1993
		US 5192415 A	09-03-1993
DE 4115795 A	12-11-1992	DE 4115795 A1	12-11-1992

EPO FORM P048

For more details about this annex : see Official Journal of the European Patent Office, No. 12/82

**This Page is Inserted by IFW Indexing and Scanning  
Operations and is not part of the Official Record**

**BEST AVAILABLE IMAGES**

Defective images within this document are accurate representations of the original documents submitted by the applicant.

Defects in the images include but are not limited to the items checked:

- BLACK BORDERS**
- IMAGE CUT OFF AT TOP, BOTTOM OR SIDES**
- FADED TEXT OR DRAWING**
- BLURRED OR ILLEGIBLE TEXT OR DRAWING**
- SKEWED/SLANTED IMAGES**
- COLOR OR BLACK AND WHITE PHOTOGRAPHS**
- GRAY SCALE DOCUMENTS**
- LINES OR MARKS ON ORIGINAL DOCUMENT**
- REFERENCE(S) OR EXHIBIT(S) SUBMITTED ARE POOR QUALITY**
- OTHER:** \_\_\_\_\_

**IMAGES ARE BEST AVAILABLE COPY.**

**As rescanning these documents will not correct the image problems checked, please do not report these problems to the IFW Image Problem Mailbox.**

**This Page Blank (uspto)**